

WEST-TRANS

SKIP LOADER

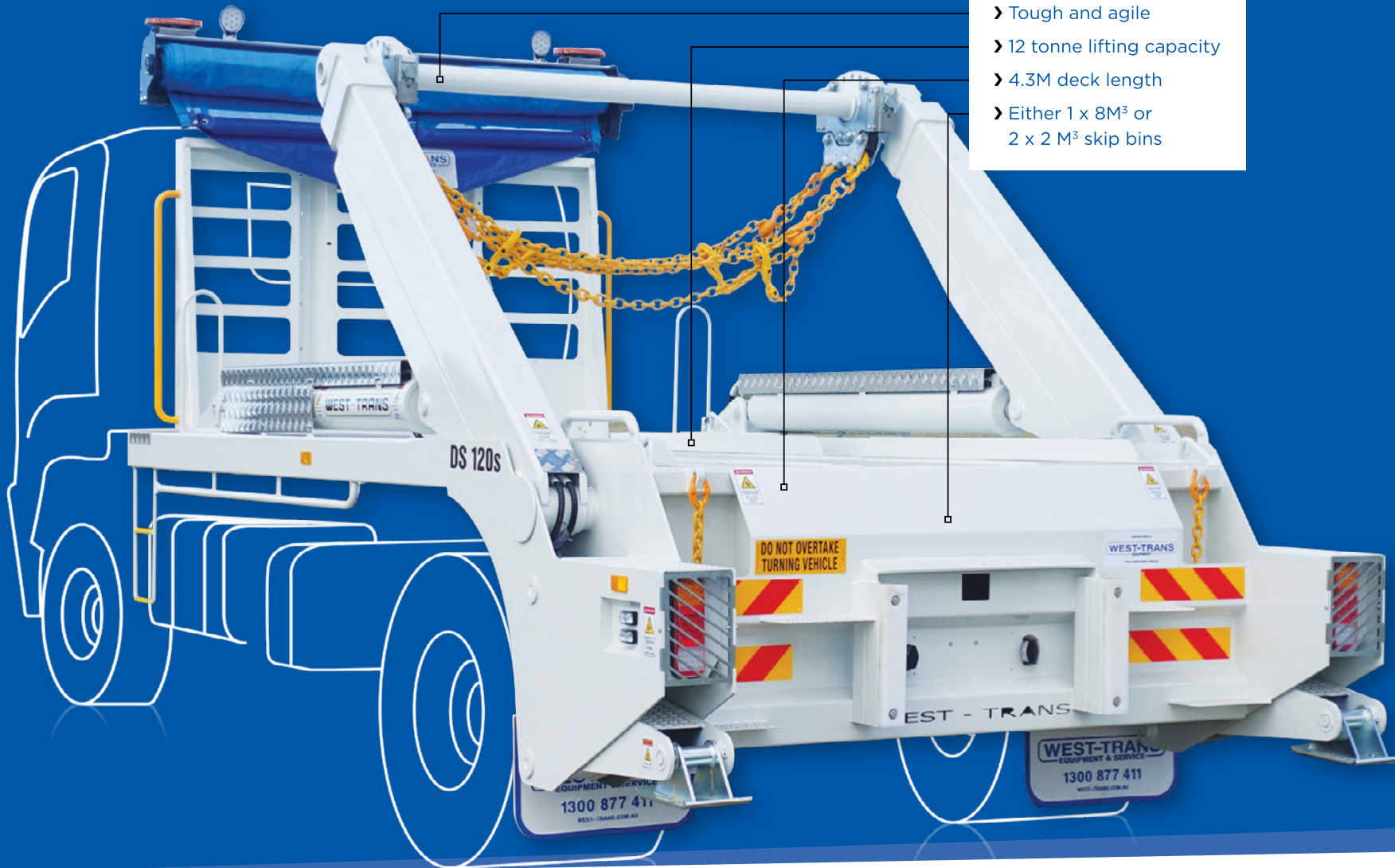

- › Tough and agile
- › 12 tonne lifting capacity
- › 4.3M deck length
- › Either 1 x 8M³ or 2 x 2 M³ skip bins

DS 120s-P

High Lift Capacity

The West-Trans DS 120s-P, is the work-horse of the Australian skip industry. Supplied with a standard 4.3M deck, and optimised to high horsepower applications, the DS 120s-P features high capacity pivoting rear stabilisers, fabricated lifting arms and familiar heavy duty load board design.

With West-Trans engineered-in toughness and durability, the DS 120s-P is purpose built for handling 2 x 2 cubic meter bins, or a single 8 cubic meter bin. Like all of the West-Trans Skip and Hook loaders, it is craftsmen built in our factory in Mulgrave (NSW), from high quality parts and materials, and ready to work hard for years.

Being designed and manufactured in Australia, they are, of course, built to meet or exceed all relevant Australia Design Rules, but more

importantly, they are built to handle the toughest conditions Australia can through at them.

All West-Trans skip loaders are protected with an anti-corrosion primer base coat, and 2 coats of high gloss colour.

Speak to a West-Trans sales professional today, or go to the website west-trans.com.au for more details.

Call 1300 877 411 or visit west-trans.com.au

WEST-TRANS
EQUIPMENT

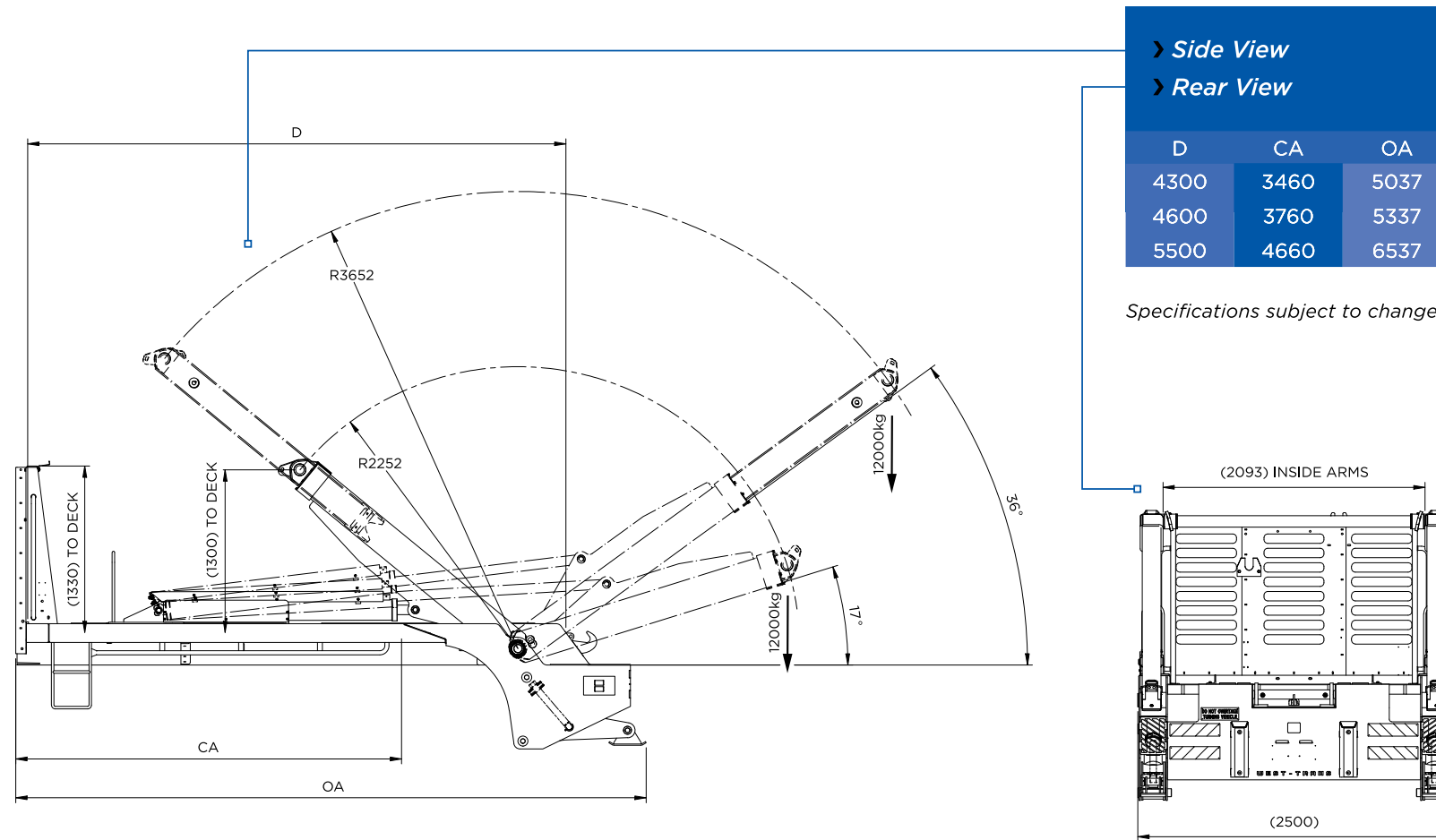

This popular model is designed around the major truck manufacturer's standard single drive chassis in the 15,000-16,000kg GVM, MWB range and with a choice of 2 standard deck lengths available, most fitting without modification.

Of course, being built in Australia, you can choose a custom build, accommodating tipping chains, your choice of colour, or the addition of a range of accessories and modifications.

Recommended Cab Chassis:

- › GVM 15,000-16,000kg
- › 4x2 4300mm wheel base (min 3460mm Cab to axle)

Choose a **West-Trans** skip loader. **Built tough in Australia.**

Options:

- › Radio Remote Control
- › Additional tie down points
- › Amber Flashing Beacons
- › Tool Boxes
- › Work lights
- › Broom and Shovel Brackets
- › Tarping Systems
- › Special surface coatings
- › Extended deck options and designs available by special build